



AUTOMOTIVE

HEAT TREATMENT EQUIPMENT  
CRANKSHAFT



## TRANSFER TYPE

### MACHINE FEATURES

- 350 kW / 5-30 kHz (bearings, 2x)
- 100 kW / 5-30 kHz (flange + shaft end, 1x)
- Production rate: 30 sec/pc
- Part size: up to 1500 mm
- Optional fillet hardening
- Loading/unloading: automatic via conveyor
- Automatic part indexing

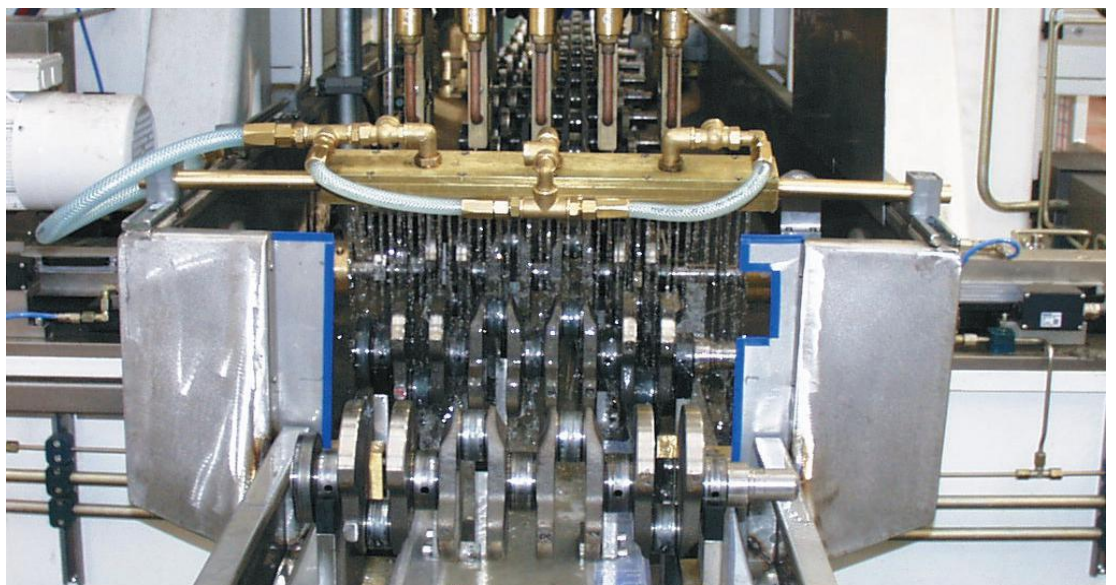

# HEAT TREATMENT EQUIPMENT CRANKSHAFT

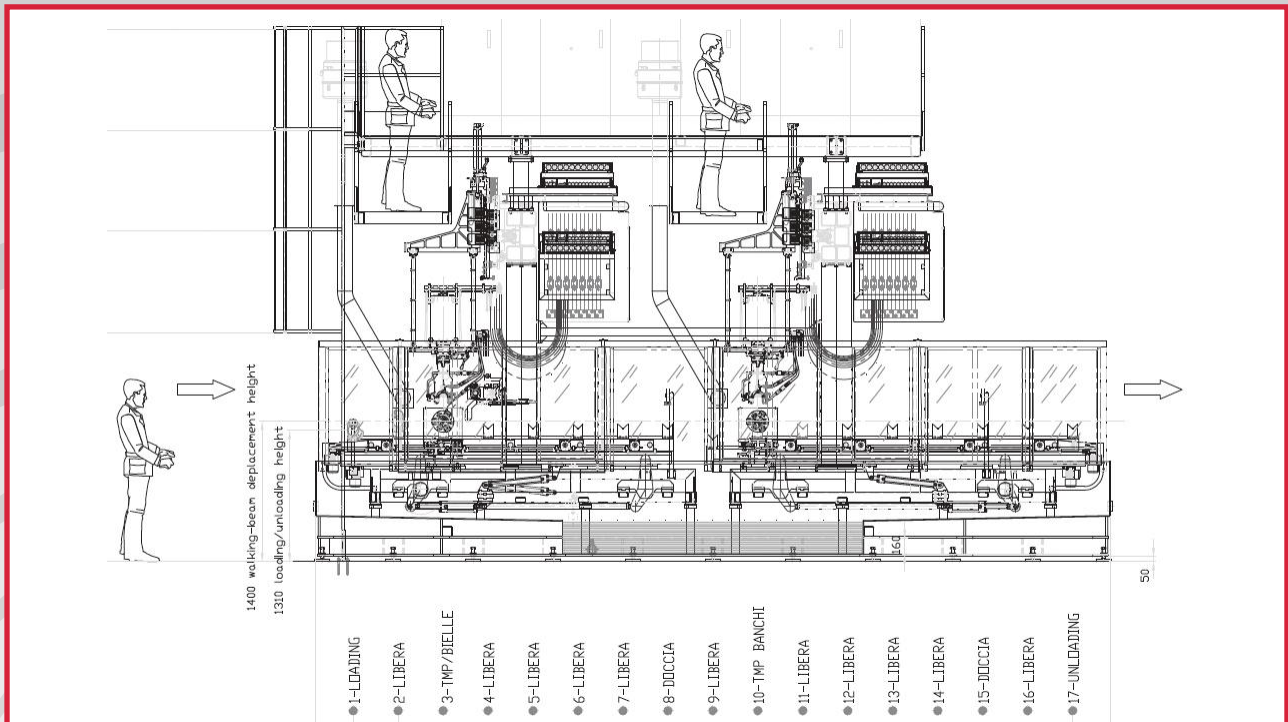

## TRANSFER TYPE

### MACHINE FEATURES

- 250 kW / 5 -30 kHz (bearingsflange + shaft end, 4x)
- Production rate: 88 sec/pc (6-cyl)
- Part size: 500-1000 mm
- Optional fillet hardening
- Loading/unloading: automatic via conveyor
- Automatic part indexing

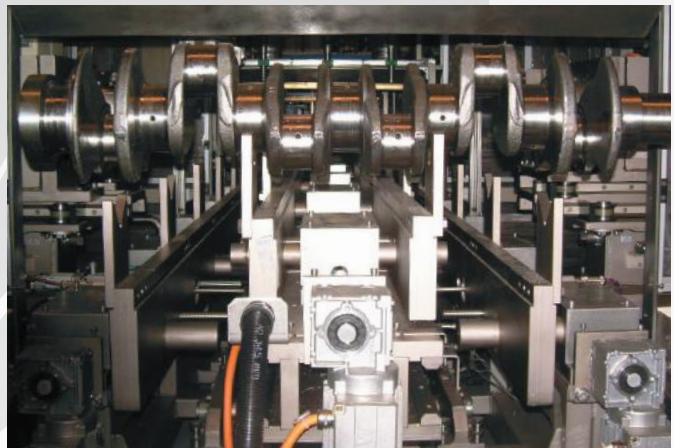

SAET S.p.A ■ Via Torino, 213 ■ 10040 Leinì (To) Italy  
Phone (+39) 011 99.77.999 ■ Fax (+39) 011 99.74.328

[www.saetemmedi.com](http://www.saetemmedi.com)